

PRODUCT CATALOG

Multi-Layer Composite Pipes (PE-AL-PE)
Paired with EZ-FIT Compression fittings



JINDAL
MLCPIPES®

www.jindaltubes.com/mlc-pro



INSPIRING INNOVATION



Jindal Tubes, a flagship company of the DS Jindal Group, is a trusted and established name in India's plumbing pipe industry, backed by decades of manufacturing expertise and industrial legacy. Built on a foundation of engineering discipline, reliability, and long-term value creation, the company has consistently focused on developing practical, high-performance solutions suited to Indian conditions.

Driven by innovation, Jindal Tubes pioneered the introduction of Multi-Layer Composite (MLC) Pipes in India offering a stronger, safer, and more advanced alternative to conventional piping systems. With multiple state-of-the-art manufacturing units, the company ensures consistent quality, scalable capacity, and dependable supply across the country.

Continuing this journey, Jindal Tubes is expanding into Silent PP Drainage Pipes, engineered to deliver superior sound insulation and improved drainage efficiency for modern infrastructure. This expansion reflects the Group's ongoing commitment to simple, durable, and future-ready plumbing solutions, rooted in trust, quality, and Indian manufacturing excellence.

100+
Channel Partners

60+
Years of Legacy

900+
Projects completed

No.1

INDIA'S LARGEST MANUFACTURER OF MULTI-LAYER PIPES



Andhra Pradesh Unit – Est. 2026

Three times larger and engineered as a next-gen smart factory, our Andhra Pradesh unit supercharges capacity and technology. With advanced MLC lines and India's latest Acoustic PP Pipe systems, it puts Jindal Tubes at the forefront of plumbing innovation and manufacturing excellence.



Dehradun Unit – Est. 2005

Among India's first MLC manufacturing units, our ISO-certified Dehradun facility laid the groundwork for Jindal Tubes' leadership. Powered by European machinery, automated extrusion lines, and a full in-house testing lab, it delivers consistent quality and reliability in every meter.

JINDAL MULTI-LAYER COMPOSITE PIPE (PE-AL-PE)

Jindal MLC Pipes combine the advantages of metal and plastic pipes and eliminate the disadvantages of both materials at the same time. The aluminium core is absolutely diffusion tight and reliably prevents oxygen or gases from permeating into the pipe. It compensates and reduces snap-back forces and heat expansion with changes in temperature.

SIZE RANGE	COIL LENGTH
16mm	200 mtr
20mm	200 mtr
25mm	100 mtr
32mm	100 mtr
40mm	100 mtr
50mm	50 mtr
63mm	6 mtr
75mm	6 mtr



Adhesive Layers

The adhesive layer perfectly bonds the polyethylene and aluminium layers and absorbs the eventual shifting movements between the layers.

Aluminium Core

The aluminium core stays where it lays and has high mechanical strength. It has the ability to withstand high temperatures and pressure. The aluminium core acts as the pipe's backbone with its mechanical resistance to deformation.

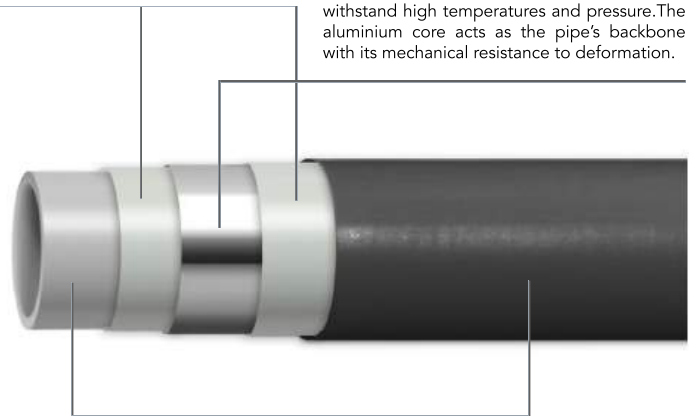

Internal & External Polyethylene Layers

The Polyethylene layers are lightweight, flexible and chemically inert. It Provides a smooth surface for better flow and is a food grade material.

JOINT-FREE PIPING SYSTEM
Available in coils of upto 200 Mtrs

JINDAL



50 Years of working life



Hygienic, Toxic free, Rust free and no growth of micro-organisms



30% more flow of fluid than in metal pipes



Easily bendable never springs back



Easy installation and wide range of usage



Light in weight, easy to carry and store



Low expansion and contraction



Quite flow



Fire retardant

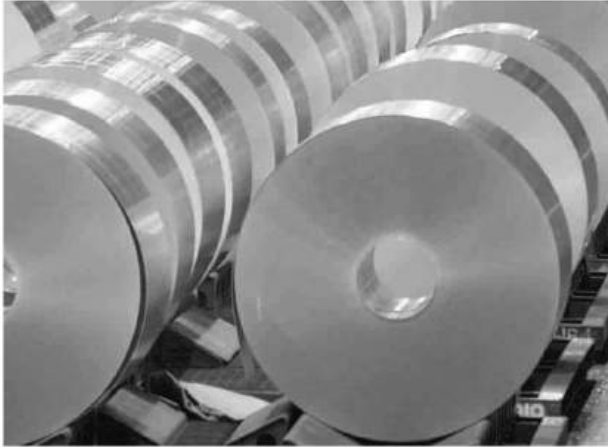

Raw Material - ALUMINIUM

Aluminum is a soft, lightweight, non-toxic and malleable metal with appearance ranging from silvery to dull gray depending on surface roughness. Aluminum alloys have yield strengths ranging from 200 mpa to 600 mpa. For Jindal MLC Pipes, a specialized grade of Aluminum is used which is manufactured specifically for these pipes and have the right balance of strength and flexibility as required for bending applications.

1 MPa = 145 psi = 10 bar = 10kg

SPECIFICATION (mm)	BURST PRESSURE (MPa)	PIPE RING STRENGTH (N)	HYDROSTATIC STRENGTH (MPa)	WORKING TEMPERATURE (°C) PIPE UV	WORKING TEMPERATURE (°C) PIPE PERT	WORKING PRESSURE (MPa)
1216	6.0	2300	2.7	-20° ~ 80°	-20° ~ 95°	1.0
1620	5.0	2500	2.7			
2025	4.0	2500	2.5			
2532	4.0	2700	2.5			
3240	4.0	3200	2.1			
4050	3.8	3500	2.1			
5163	3.8	5200	2.1			
6375	3.8	6000	2.1			

THERMAL CONDUCTIVITY : 0.45W/m.k. - about 1/100 of steel pipe but not only several times higher than that of insulating materials. No need of insulation with Jindal Hot Water MLC pipes. Jindal MLC Pipes have an extremely low co-efficient of linear expansion 25×10^{-6} m/m.k., Only 1/8th of all polyethylene pipes, almost same as that of aluminum pipes.

Raw Material - POLYETHYLENE

Polyethylene or PE is a polymer consisting of long chains of the monomer ethylene. It is created through the polymerization of ethene and is classified into different types based on Density. High Density Polyethylene or HDPE is used to manufacture Jindal MLC Pipes. It has a low degree of branching and thus stronger inter- molecular forces and tensile strength. The HDPE used in Jindal MLC Pipes is food grade and hence hygienic.



EZ-FIT COMPRESSION FITTINGS



EZ Fittings combine the positive feature of high reliability with a simple installation technique that does not require any special tools. The permanent pipe joint is achieved by compression i.e. tightening the nut against the tapered split ring. The profiles of the two pieces are designed to cause a progressive shrinkage of the split ring and to distribute the compression forces across the contact surface. A seal housing has been designed with a special slip-proof profile called O-Rings that come into direct contact with the pipe

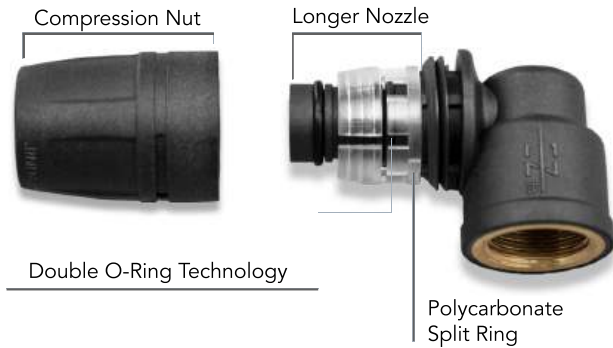

EZ Fittings are made from high quality engineering Nylon using advance injection moulding that makes it extremely reliable and reluctant to leakages. The fittings are rigid and lightweight at the same time.

The simplicity and economic aspect of this system is based on the use of spanners, standardised threads, which make it possible to connect with any system.

EZ Fittings come in 3 Categories as listed below:

EZ-FIT

- Full Plastic component
- Developed with advanced injection moulding
- Lightweight & Economical
- Removable and Reusable
- Quick and simple installation



EZ-HYBRID

- Brass Male thread with Plastic Nozzle
- Hybrid Technology
- Strength of Brass combined with the cost effectiveness of plastic
- Removable and Reusable
- Quick and simple installation



EZ-BRASS

- Full Brass Body
- Plastic Compression Nut and Split ring
- Superior Strength
- Removable and Reusable
- Quick and simple installation



INSTALLATION GUIDE



1 Cut the pipe from a perpendicular angle using the **Pipe Cutter**



2 Round and chamfer the pipe using a **reamer** with 3-5 rotations for proper insertion



3 Use the Internal/External **Bending Springs** for bending the pipe to avoid dents



4 Disassemble the fitting



5 Put the nut & Split ring over the pipe

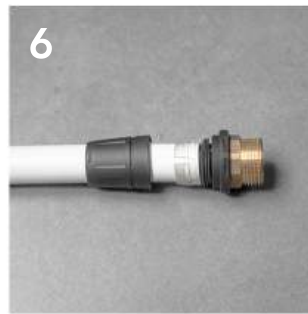

6 Insert the fitting into the end hole



7 Tighten the nut

PRODUCT RANGE

*Available in 16mm, 20mm, 25mm, 32mm, 40mm & 50mm



Equal Tee



Unequal Tee



Equal Union



Unequal Union



Equal Elbow



Unequal Elbow



Female Elbow



EZ-BRASS Female Elbow



Male Union



EZ-BRASS Male Union



Female Union



EZ-BRASS Female Union



Female Tee



EZ-BRASS Female Tee



Pipe End



No.1

INDIA'S LARGEST MANUFACTURER OF MULTI-LAYER PIPES

KWJET PRO / © 2025 JINDAL PEX TUBES PVT. LTD. ALL RIGHTS RESERVED

Jindal Pe-x Tubes Pvt Ltd
DSM-311-312, 3rd Floor,
DLF Tower, Shivaji Marg,
Moti Nagar, New Delhi - 110015

Helpline: +91 875 0075 007
+91 906 0700 000

Info@jindaltubes.com
www.jindaltubes.com

JINDALTUBES
A Unit of D.S. Jindal Group